

GEN. ST.	01	02	03	04	05	06	07	08	0D	50	60	70	80	90																	
INT. ST.	10	11	12	13	14	18	20	31	32	33	34	38	39	40	42	43	44	45	46	48	56	70	72	73	75	76	81	82	83	84	88

REV.	DATE	DESCRIPTION	BY	C'K'D'
A	2001-09-14	CONVERSION REVISION 03	KN	
B	2005-10-26	105-0205	ALEX B	BKP
C	2006-08-08	106-0144	ALEX B	BKP

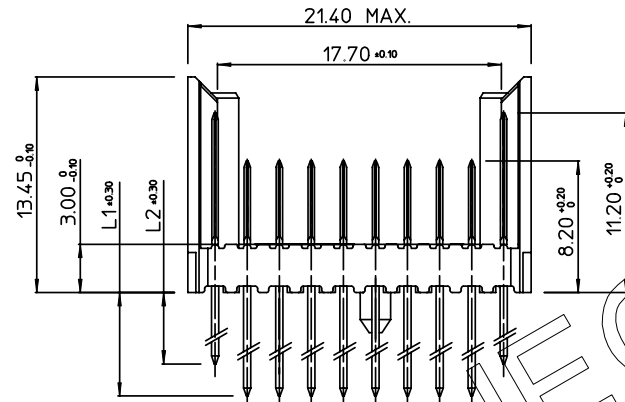
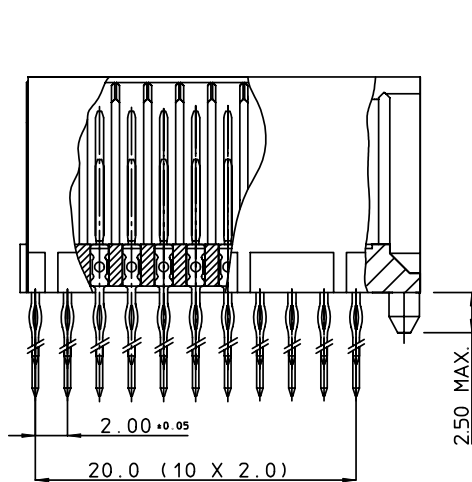

PERFORMANCE CHARACTERISTICS

CURRENT RATING : 1.5 A AT 20°C (FULLY LOADED)
 1 A AT 70°C (FULLY LOADED)
 RATED VOLTAGE : 500 V AC (CONT / CONT)
 OPERATING TEMPERATURE : -55°C TO 125°C
 CONTACT RESISTANCE : 20 mΩ MAX
 INSERTION FORCE : 0.60 N MAX / CONT
 EXTRACTION FORCE : 0.15 N MIN / CONT
 INSULATION RESISTANCE : 10⁴ MΩ MIN

CAT. NR.	L1+0.3	L2+0.3	DESCRIPTION
HM2P89PD8111----	3.7	3.7	SHORT PRESS-FIT
HM2P89PC8111----	4.5	4.5	SHORT PRESS-FIT
HM2P89PK8111----	13	4.5	REAR PLUG-UP: LEVEL 1
HM2P89PM8111----	14.5	4.5	REAR PLUG-UP: LEVEL 2
HM2P89PN8111----	16	4.5	REAR PLUG-UP: LEVEL 3
HM2P89PT8111----	13	4.5	WIRE WRAP

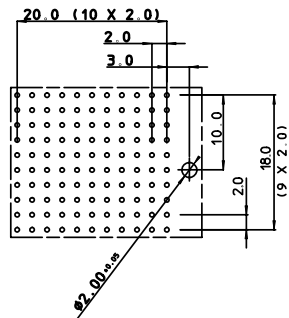
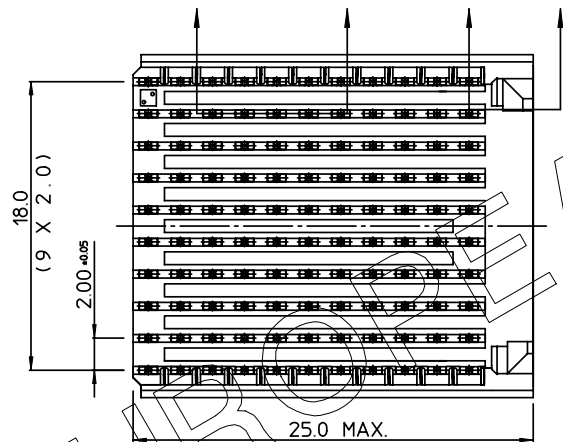

LAY-OUT
P.C.B. - HOLE

NOTES

- *HM2P89P#5111*
 PERFORMANCE LEVEL INDICATOR (REFER DWG No. BS,C ,201844,003)
 LEAD FREE INDICATOR : LF=LEAD FREE (DIGIT 15&16)
- THIS PRODUCT IS CSA APPROVED.
 THIS PRODUCT IS UL RECOGNIZED.
- FOR RECOMMENDED PTH DIMENSIONS REFER DRAWING : BS,A ,201572,001
- THE PRODUCT (LF) MEETS EUROPEAN UNION DIRECTIVES AND OTHER COUNTRY REGULATIONS AS DESCRIBED IN GS-22-008

MALE SIGNAL STRAIGHT PRESS-FIT-TO-BOARD CONNECTOR				
EXTENSION MODULE (WIDE BODY)				
1DEC ±0.2 2DEC ±0.1 ANGLES ±1°	APPR.	DATE	SIGN.	MILLIPACS 2 / TYPE F (8 ROW) / SHIELDED
	DRAFT	1996-04-30	W.Panis	CAT. No. HM2P89P#8111----
	CHECKED			
WE RESERVE THE RIGHT TO CHANGE DIMENSIONS OR REQUIREMENTS WITHOUT PRIOR NOTICE.	PROD. MGR.			SCALE
	PR. ENG. MGR.			3/1
	PR. MGT. MGR.			
ALL DIMENSIONS IN MM	REFERENCES		www.fciconnect.com	

THIS IS OUR EXCLUSIVE PROPERTY. IT IS NOT TO BE COPIED, REPRINTED OR DISCLOSED TO A THIRD PARTY, NOR USED FOR MANUFACTURING WITHOUT OUR WRITTEN CONSENT, AND HAS TO BE RETURNED TO US IN CASE OF NO USAGE
 DIT IS ONZE EIGENDOM EN MAG NIET NAGEMAAKT, HERDRUKT, OVERGEMAAKT AAN DERDEN, NOCH VOOR FABRIKATIE GEBRUIKT WORDEN, ZONDER ONZE SCHRIFTELIJKE TOELATING. BIJ NIET GEBRUIK IS TERUGZENDING VERPLICHT.

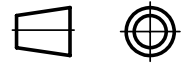

PDM: Rev:C